

# Tusk Digital Radiator Fan Kit (1942350001)



Congratulations on your purchase of this digital fan kit! This product is made to help keep your machine running at a safe operating temperature during extreme conditions. Please take note of the information and instructions below to get the most out of your Tusk Product.

**Note:** For instructional videos, refer to [www.rockymountainatvmc.com/videos](http://www.rockymountainatvmc.com/videos).

**Assembly:** Before you throw any packaging away, make sure you received all the necessary hardware:

## Fan Install Steps:

1. Be sure to check the measurements of the fan and the room you have behind your radiators. This kit can work with most radiator braces and fuel tanks but verify fitment before install. **Note: will work on either side radiator.**

To begin the install process, you may need to remove your seat, fuel tank/radiator shrouds and louvers to help with the install. This will allow you more access to either the right side or left side radiator and aid in the installation of the fan. Once these items are removed, take the fan and fit it up to the back side of the radiator to find the best placement. You will want the fan to sit as flush against the radiator as possible.

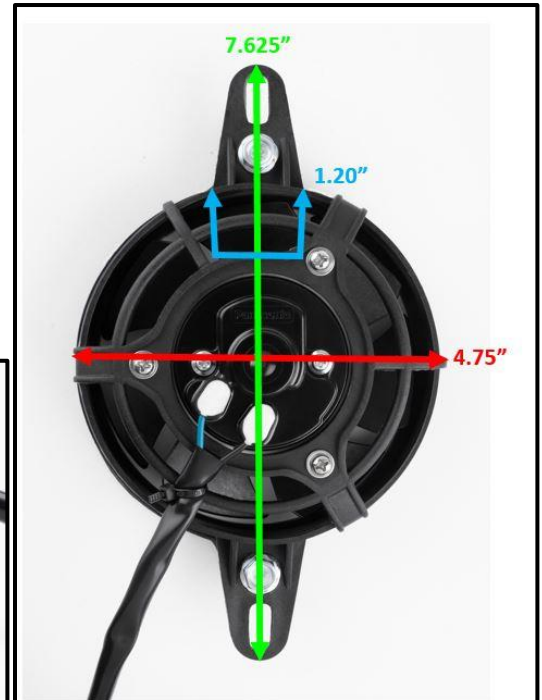

2. Ensure the fan will clear your frame, electronics, coolant lines, radiator braces, etc.... Once you find the desired placement, take 2 of the included plastic locking ties and push them through the 2 exposed holes in the fan mount, through the radiator fins and out the front of the radiator. (Make sure plastic ties are centered in the fins between the water jackets.) Now take 2 of the foam squares and slide them over the ends of the plastic locking ties with the sticky side facing out and slide them until they touch the radiator. Then take 2 of the plastic locking nuts and slide them over the locking ties, slide them until they are against the foam squares. Now tighten the locking nuts down until they are squeezing the foam squares against the radiator and the fan is securely mounted to the backside.

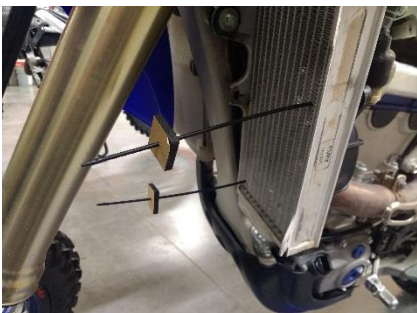

# Tusk Digital Radiator Fan Kit (1942350001)



- Once the fan is securely mounted to the radiator, you can cut the excess plastic locking tie from the front of your radiator (leaving 2-3 locking rings exposed) and reinstall your radiator louvers. Take the radiator fan thermostat box and remove all the contents. Inside the white box you will find a temperature sensor probe and thermal grease. You will need to find a location in your radiator fins to insert this probe (above or below the fan will work just fine.) Open the thermal grease and squeeze half the tube into a single radiator fin. Then carefully press the end of the temperature sensor into that radiator fin. Ensure that the temperature sensor is in all the way. **Note: Use of safety wire is recommended to keep probe inside the radiator during extreme uses.**

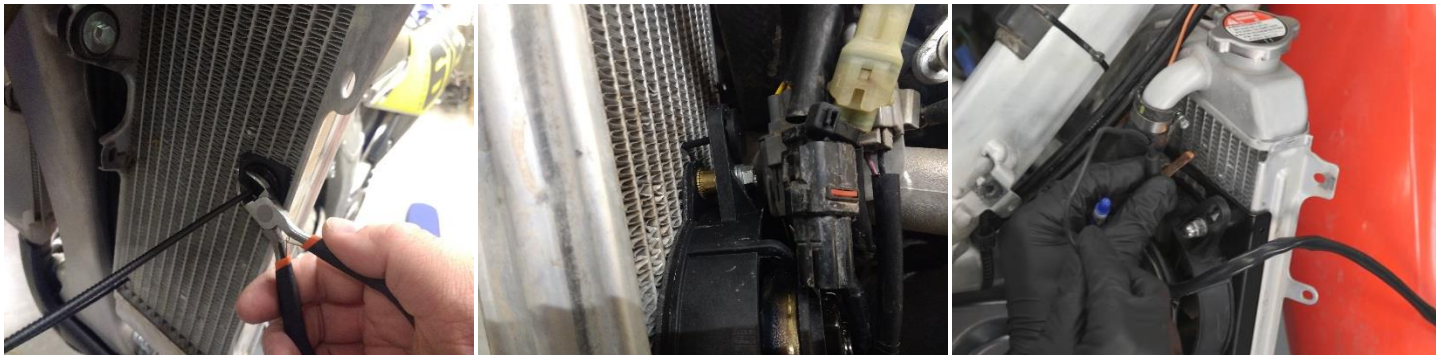

- Now taking the radiator fan harness that comes included, route the 2-pin connector from the battery and follow the OEM wire harness until the connector reaches the area around the ignition coil. Be sure to avoid areas with pinch points or excessive heat. Wait until the fan and thermostat are hooked up before connecting this harness to the battery.
- Locate a place to mount the digital thermostat. A common place is on the frame in front of the gas cap or on the right side of the frame in front of the radiator cap. Once the desired location is found, clean both the back of the thermostat and the mounting location (do not use brake/carburetor cleaner.) Install the tape onto the back of the thermostat then stick the thermostat to the desired location. Multiple pieces of tape have been included so that you can cut and mount the tape to achieve the most contact between thermostat and frame as possible. Once the thermostat has been mounted, route the wires along the frame towards the ignition coil area. You can then connect the power harness, fan and temperature sensor connector to the matching connectors (use of dielectric grease is recommended.)

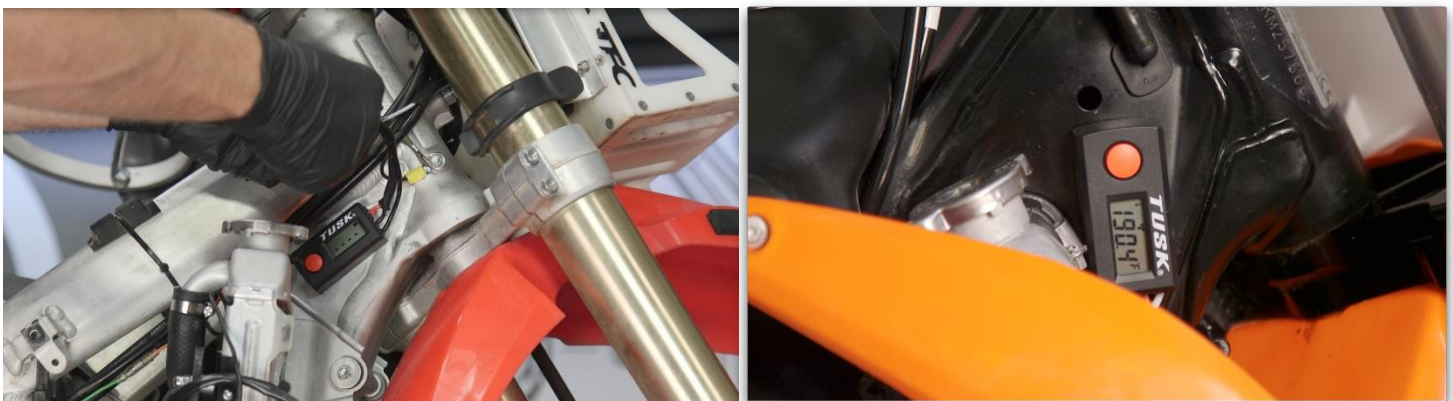

## Tusk Digital Radiator Fan Kit (1942350001)



6. Use the supplied plastic ties to secure the wiring away from the fan, any pinch points or excessive heat. Be sure that you have proper function of steering and all other controls. Once everything is connected, you can connect the power harness to the battery (black to the negative, red to the positive) and ensure proper function of the thermostat according to the instructions included with the meter.
7. Once everything is connected and functioning properly, ensure the coolant is filled, reinstall the radiator louvers, fuel tank/shroud and seat according to OEM specs.
8. Start your machine in a well-ventilated area and check for leaks and proper function of the fan kit. The thermostat will come preset to start at 190 degrees F. This is a recommended operating temperature for most off-road vehicles. Please check instructions included with the thermostat for more details about the functions of the digital thermostat.

**Notes: Make sure plastic locking ties are tight before each ride. Be sure that the temperature sensor is tightly mounted into the radiator fins before each ride. Ensure proper function of the radiator fan before every ride. Failure to follow these procedures can lead to a void in warranty.**

# **NOTICE**

**Take care when handling the Temperature Sensor. When using plastic ties, secure the Temperature Sensor wire with minimal force to prevent damage. Pulling, tugging, or any other abuse to the wire can and will lead to product failure.**

**Replacements available online at  
[www.rockymountainatvmc.com](http://www.rockymountainatvmc.com).**